

- » Sleek design with NEW 18 mm width in accordance with DIN norm
- » Conforms to IEC 61812-1 + UL 508
- » Wide input power supply range (12-240 V AC/DC)
- » Wide and easily adjustable time range
- » LED notifications
- » High sensitivity and switching capacity
- » High mechanical endurance

STEP 1

Model Name	Order No	Mode	Timing Range
Z1T-LR.2	261020	LR	0.1 sec.. 10 days
Z1T-SD	261021	SD	1 .. 30 sec, 20 .. 500 msec
Z1T-SD-500	261022	SD	1 .. 30 sec, 20 .. 500 msec



Operating Voltage	12..240V AC/DC ±10% 150..500V AC (for Z1T-SD-500)
Operating Frequency	45..65Hz
Power Consumption	DC < 1.5 W
	AC < 5 VA < 10 VA (for Z1T-SD-500)
Relay Outputs	Number and Type of Contacts 2 C/O (for Z1T-LR.2) 2 NO (for Z1T-SD and Z1T-SD-500)
	Maximum Switching (Voltage/Current/Power) 115 VAC / 10A / 1250 VA 250VAC / 5 A / 1250 VA 125VAC / 8A / 2000 VA (for Z1T-SD-500)
Cable Cross Section	2.5mm ² / AWG 14-30 solid or stranded
Screw Tightening Torque	0.5 Nm / 4.5 lb-inch
Cable Stripping Size (Min / Max)	8mm / 9mm
Operating Temperature Range	-20 / +60 °C
Max Surrounding Air Temperature	60°C (55°C for Z1T-SD-500)
Protection Degree (IEC 60529)	IP 20
Pollution Degree	2

NOTE: Use 60/75°C copper (CU) wire only. (75°C for Z1T-SD-500)

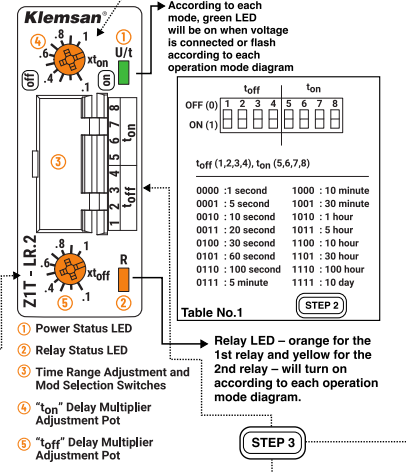
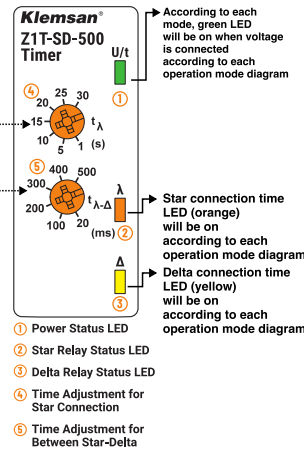
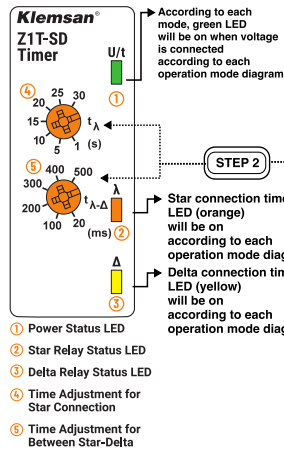
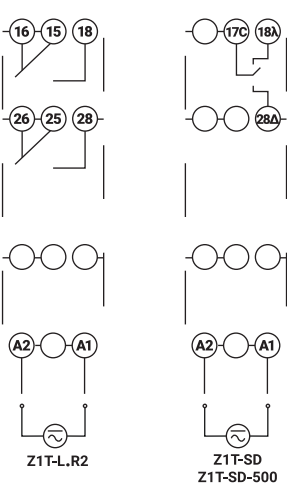
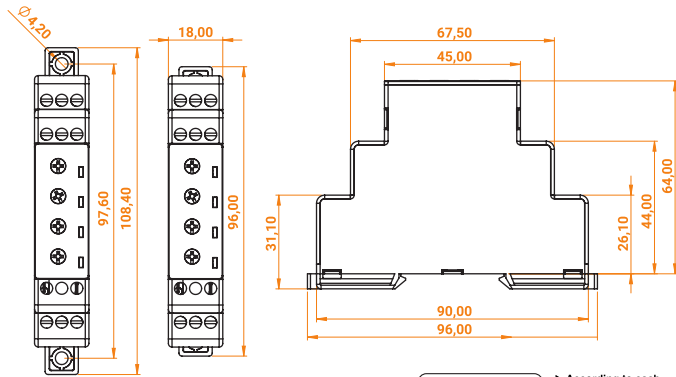

STEP 1

OPERATION MODE	FUNCTION ILLUSTRATION	FUNCTION STATEMENT
Mode: LR	<p>Left-Right Timer</p> <p>R1: </p> <p>R2: </p> <p>U/t: </p>	Initially first relay is energized. After the adjustable time delay t _{on} , relay is de-energized. Both relays are de-energized during adjustable time delay t _{off} . At the end of toff, second relay energizes. Second relay stays in this position during ton. When ton finished both relays are de-energized. This cycle is repeated continuously.
Mode: SD	<p>Star-Delta Timer</p> <p>R_λ: </p> <p>R_Δ: </p>	When energy applied to device, star relay is energized until the end of the adjustable t _λ time. At the end of the adjusted delay time t _{λ-Δ} , delta relay is energized until the device is powered off.

USER ASSISTANT **SETTING THE TIMER RELAY** **Z1T-SD Z1T-SD-500**

(STEP 1) Check the device model name and understand which operating modes your device supports.

(STEP 2) Set time range from the pots No.4 and No.5

Example → For t_λ = 20 seconds → Set pot no.4 to 20s
Example → For t_{λ-Δ} = 200 milliseconds → Set pot no.5 to 200 ms

Please disconnect the power before adjusting the timers, device will start with the new settings after connecting the power

USER ASSISTANT **SETTING THE TIMER RELAY** **Z1T - LR.2**

(STEP 1) Check the device model name and understand which operating modes your device supports.

(STEP 2) Select the desired time adjustment by the mode selection switches N.3 For more information review Table No.1

(STEP 3) Set time t_{on} and t_{off} multiplier from the pots No.4 and No.5

Example → For t_{on} = 20 seconds → Mode (5,6,7,8)=0011, Xt_{on} = 1
Example → For t_{off} = 1 hour → Mode (1,2,3,4)=1010, Xt_{off} = 1

Please disconnect the power before adjusting the timers, device will start with the new settings after connecting the power

- » DIN normuna uygun YENİ 18 mm genişliğinde şık tasarım,
- » IEC 61812-1 standardına uygun + UL 508
- » Geniş çalışma gerilimi aralığı,
- » Geniş ve kolay ayarlanabilir zaman aralığı,
- » LED bildirimler,
- » Yüksek hassasiyet ve anahtarlama dayanımı,
- » Yüksek mekanik dayanıklılık.

Adım 1

Ürün Adı	Sipariş No	Fonksiyon	Zaman Ayarı
Z1T-LR.2	261020	LR	0.1 sn .. 10 gün
Z1T-SD	261021	SD	1 .. 30 sn, 20 .. 500 msn
Z1T-SD-500	261022	SD	1 .. 30 sn, 20 .. 500 msn



Besleme Gerilimi	12..240V AC/DC ±10% 150..500V AC (for Z1T-SD-500)	
Besleme Frekansı	45..65Hz	
Güç Tüketimi	DC	< 1.5 W
	AC	< 5 VA < 10 VA (for Z1T-SD-500)
Röle Çıkışları	Kontakt Sayısı ve Tipi	2 C/O (for Z1T-LR.2) 2 NO (for Z1T-SD and Z1T-SD-500)
	Maksimum Anahtarlama Gerilim / Akım / Güç	115VAC / 10A / 1250 VA 250VAC / 5A / 1250 VA 250VAC/16A/2000 VA 125VAC/ 8A/2000 VA (for Z1T-SD-500)
Kablo Kesiti	2.5mm ² / AWG 14-30 tek damarlı veya çok damarlı	
Vida Sıkma Torku	0.5 Nm / 4.5 lb-inch	
Kablo Soyma Boyutu (Min / Max)	8mm / 9mm	
Çalışma Sıcaklığı Aralığı	-20 / +60 °C	
Maksimum Çevre Sıcaklığı	60°C (55°C for Z1T-SD-500)	
Koruma Derecesi (IEC 60529)	IP 20	
Kirliilik Derecesi	2	

NOT: Yalnızca 60/75°C bakır (CU) kablo kullanınız. (Z1T-SD-500 için 75°C)

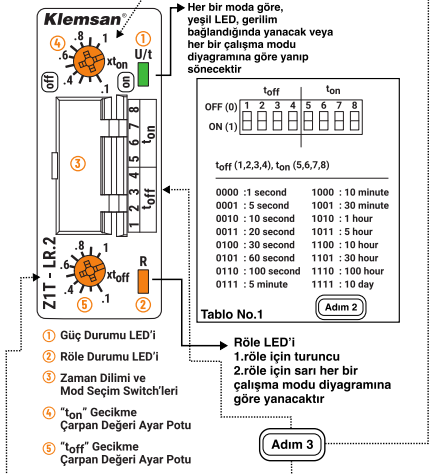
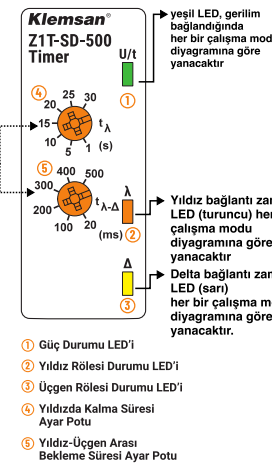
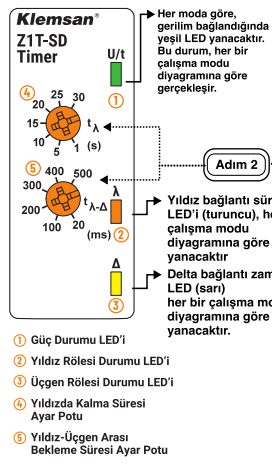
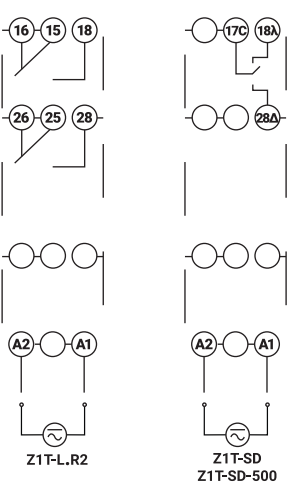
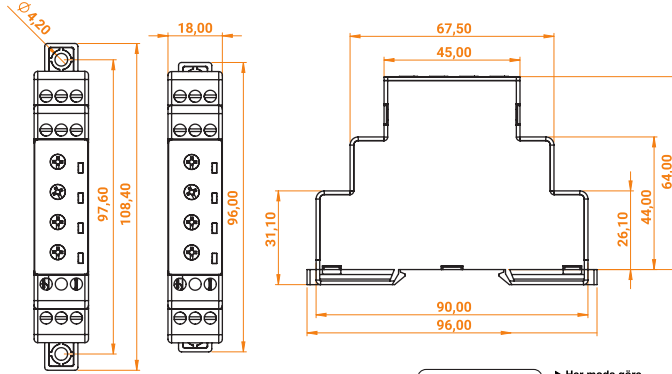

OFF (0)	1	2	3	4	5	6	7	8
toff								
ton								

toff (1,2,3,4), ton (5,6,7,8)

0000	1000
:1 second	:10 minute
:5 second	:30 minute
:10 second	:1 hour
:20 second	:5 hour
:30 second	:10 hour
:60 second	:30 hour
:100 second	:100 hour
:5 minute	:10 day

Adım 1

ÇALIŞMA MODU	FONKSİYON TANIMI	FONKSİYON AÇIKLAMASI
--------------	------------------	----------------------

Mod : LR

Sol-Sağ Rölesi

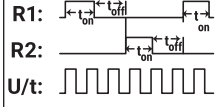

Cihaz enerjilendiği anda ilk önce birinci röle çeker. Ayarlanan t_{on} süresi sonunda röle bırakır. t_{off} süresi kadar her iki röle de enerjisiz kaldıktan sonra süre bitiminde ikinci röle çeker. İkinci röle t_{on} süresi sonunda bırakır ve t_{off} süresi kadar beklemeden sonra tekrar birinci röle çeker. Bu döngü cihazın enerjisi kesilene kadar devam eder.

Mod : SD

Yıldız-Üçgen Rölesi

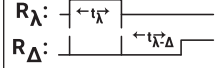

Cihaz enerjilendiği anda yıldız kontakları çeker ve ayarlanan t_{λ} süresi kadar çekili kaldıktan sonra bırakır. Ayarlanan $t_{\lambda-\Delta}$ bekleme süresi sonunda üçgen kontakları çeker ve enerji kesilene kadar üçgen kontakları konumunu korur.

ZAMAN RÖLESİNİN AYARLANMASI Z1T-SD Z1T-SD-500

(Adım 1) Cihazın model adını kontrol edin ve cihazınızın hangi çalışma modlarını desteklediğini anlayın.

(Adım 2) Zaman aralığını No.4 ve No.5 potundan ayarlayın.

Örnek → $t_{\lambda} = 20$ saniye → no.4 potunu 20s ayarlayın
Örnek → $t_{\lambda-\Delta} = 200$ milisaniye → no.5 potunu 200 ms ayarlayın

Zamanlayıcıları ayarlamadan önce gücü kesin. Cihaz, gücü tekrar bağladıktan sonra yeni ayarlarla çalışmaya başlayacaktır.

ZAMAN RÖLESİNİN AYARLANMASI Z1T-LR.2

(Adım 1) Cihazın model adını kontrol edin ve cihazınızın hangi çalışma modlarını desteklediğini anlayın.

(Adım 2) İstenen zaman ayarını, No.3 numaralı mod seçim anahtarlarıyla seçin. Daha fazla bilgi için Tablo No.1'i inceleyin.

(Adım 3) Zaman t_{on} ve t_{off} çarpanını No.4 ve No.5 potundan ayarlayın.

Örnek → $t_{on} = 20$ dakika → Mod (5,6,7,8)=0011, $Xt_{on} = 1$
Örnek → $t_{off} = 1$ saat → Mod (1,2,3,4)=1010, $Xt_{off} = 1$

Zamanlayıcıları ayarlamadan önce gücü kesin. Cihaz, gücü tekrar bağladıktan sonra yeni ayarlarla çalışmaya başlayacaktır.